

ARTIFICIAL INTELLIGENCE
TEMPERATURE CONTROLLER
AI-208 (V7.6)



User Manual

I. Model Code Symbol

The type of AI-208 is made up of 4 parts:

<u>AI-208</u>	<u>A</u>	<u>G</u>	<u>L2</u>
Part 1 (Series)	Part 2 (Size)	Part 3 (Oupt)	Part 4 (AUX)

1. (Part 1) Basal function of instrument

AI-208, standard temperature controller , 0.3%FS±1°C accuracy.

Multiple thermocouples and RTDs are selectable

Suit for 0~999°C application. Maximum support two alarms contact output

Universal voltage input (100~240VAC)

ISO9001 certification and CE certified, achieving world class level of quality, anti-interference ability and safety

2. (Part 2) Front panel dimension

Size	Front Panel width×height	Cut Out width×height	Depth Behind Mounting Surface
A	96×96mm	92×92mm	100mm
B	160×80mm	152×76mm	100mm
D	72×72mm	68×68mm	95mm
D2	48×48mm	45×45mm	95mm
E	48×96mm	45×92mm	100mm
F	96×48mm	92×45mm	100mm

3. (Part 3 and 4) indicate the module installed in OUP and AUX sockets.

Allowed modules in each socket are as below:

Allowed Type Module Socket	N	L	L1	L5	G
3. OUP (main output)		√			√
4. AUX (Auxiliary output)	√		√	√	

- N** (or none) no module installed
- L** Relay contact output module (Capacity: 5A/250VAC or 5A/30VDC, normal open)
- L1** Relay contact output module (Capacity: 2A/250VAC, small volume)
- L5** Output module of dual normal open relay contact (Capacity: 2A/250VAC, support AU1 and AU2 alarm output)
- G** SSR voltage output module (30mA/5VDC)

II. TECHNICAL SPECIFICATION

1. **Input type :**
 Thermocouple: K, E, J, N
 Resistance temperature detector: Pt100
2. **Instrument Input range :**
 K, E, J, N : (0~+999)°C ; Pt100: (0~+800)°C
3. **Measurement accuracy : 0.3%FS±1°C**
4. **Temperature display resolution : 1°C**
5. **Control mode:**
 On-off control mode, or
 AI artificial intelligence control, including fuzzy logic PID control and advanced control algorithm with the function of parameter auto tuning.
6. **Alarm function:** High limit alarm, Lower limit alarm, Deviation High Alarm.
7. **Power supply voltage rating:** 100-240VAC, -15%, +10% / 50-60Hz.
8. **Power consumption:** ≤2W
9. **Ambient temperature:** -10~+60°C, Humidity: 0~90RH%

III. FRONT PANEL AND OPERATION

- ① Process Value(PV), or parameter code
- ② Set Value(SV), alarming code, or value of a parameter
- ③ Setup key, for accessing parameter table, and confirming change.
- ④ Data shift key, also for activating auto turning
- ⑤ Data decrease key
- ⑥ Data increase key
- ⑦ Status display LED

Basal display status:

When power on, will shows the process value (PV) and the set point (SV).

If the input signal is out of the measurable range (for example, the thermocouple or RTD circuit is break, or input specification sets wrong),

Will alternately display "orA", and limit alarm of PV, moreover instrument will automatically stop the output.

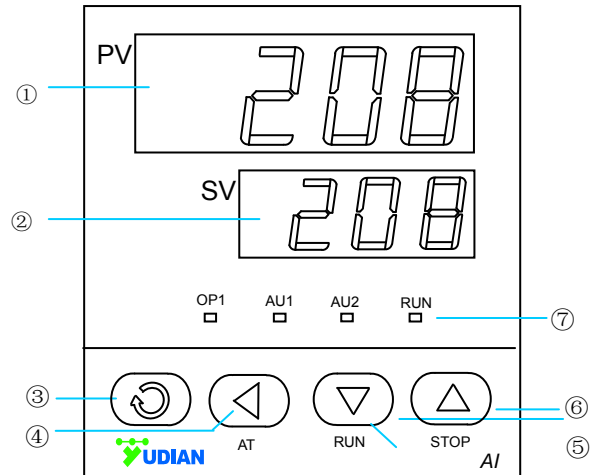

IV. OPERATION DESCRIPTION

● Set Value Setting:

In basal display status, if the parameter lock "Loc" isn't locked, we can set setpoint (SV) by pressing \leftarrow , \downarrow or \uparrow . Press \downarrow key to decrease the value, \uparrow key to increase the value, and \leftarrow key to move to the digit expected to modify. Keep pressing \downarrow or \uparrow , the speed of decreasing or increasing value get quick. The range of setpoint is between the parameter SPH. The default range is 0 to 400.

● Parameter Setting:

In basal display status, press \odot and hold for about 2 seconds can access Field Parameter Table. Pressing \odot can go to the next parameter; pressing \leftarrow , \downarrow or \uparrow can modify a parameter. Press and hold \leftarrow can return to the preceding parameter. Press \leftarrow (don't release) and then press \odot key simultaneously can escape from the parameter table. The instrument will escape automatically from the parameter table if no key is pressed within 30 seconds. Setting Loc=808 and then press \odot can access System Parameter Table.

● AI artificial intelligence control and auto tuning

When AI artificial intelligence control method is chosen (CrL=AI), the PID parameters can be obtained by running auto-tuning. In basal display status, press \leftarrow for 2 seconds, the "At" parameter will appear. Press \uparrow to change the value of "At" from "oFF" to "on", then press \odot to active the auto-tuning process. During auto tuning, the instrument executes on-off control. After 2-3 times of on-off action, the instrument will obtain the optimal control parameter value. If you want to escape from auto tuning status, press and hold the \leftarrow key for about 2 seconds until the "At" parameter appear again. Change "At" from "on" to "oFF", press \odot to confirm, then the auto tuning process will be cancelled.

Note 1: If the setpoint is different, the parameters obtained from auto-tuning are possible different. So you'd better set setpoint to an often-used value or middle value first, and then start auto-tuning. For the ovens with good heat preservation, the setpoint can be set at the highest applicable temperature. Depending on the system, the auto-tuning time can be from several seconds to several hours.

Note 2: Parameter Ctl (on-off differential, control hysteresis) has influence on the accuracy of auto-tuning. Generally, smaller value of Ctl can get higher the precision after auto tuning. But Ctl parameter value should be large enough to prevent the instrument occur error action around setpoint due to the oscillation of input. Ctl is recommended to be 2.0.

Note 3: AI series instrument has the function of self-learning. It is able to learn the process while working. The control effect at the first run after auto tuning is probably not perfect, but excellent control result will be obtained after a period of time because of self-learning.

V. PARAMETER AND SETTING

Field parameter table (Press  and hold for 2 seconds to access)

Code	Name	Description	Setting Range																				
HIA	High limit alarm	Alarm on when PV (Process Value) >HIA; alarm off when PV<HIA-AHY	0~999℃																				
LoA	Lower limit alarm	Alarm on when PV (Process Value) < LoA; alarm off when PV > LoA+AHY	0~999℃																				
HdA	Deviation high alarm	Alarm on when PV-SV>HdA; alarm off when PV-SV<HdA-AHY	0~999℃																				
Loc	Parameter lock	Loc=0~1: Allowed to modify parameters HIA, LoA, HdA and SV. Loc=2~3: Allowed to modify parameters HIA, LoA, HdA. But cannot change SV. Loc=4~255: NOT allowed to modify any parameters and SV. Loc=808, Set to 808 and press  , allowed modify all parameters.	0~255																				
AHY	Hysteresis	Avoid frequent alarm on-off action because of the fluctuation of PV, usually sets to AHY=2	0~200																				
AOP	Alarm output assignment	<table border="1"> <tr> <td>Alarm Output to</td> <td>HdA (x100)</td> <td>LoA (x10)</td> <td>HIA (x1)</td> </tr> <tr> <td>None</td> <td>0</td> <td>0</td> <td>0</td> </tr> <tr> <td>AU1</td> <td>1</td> <td>1</td> <td>1</td> </tr> <tr> <td>AU2</td> <td>2</td> <td>2</td> <td>2</td> </tr> </table> <p>eg: AOP=201 means HdA have alarm action from AU2, LoA, no alarm action , HIA alarm action output from AU1.</p>	Alarm Output to	HdA (x100)	LoA (x10)	HIA (x1)	None	0	0	0	AU1	1	1	1	AU2	2	2	2	0~444				
Alarm Output to	HdA (x100)	LoA (x10)	HIA (x1)																				
None	0	0	0																				
AU1	1	1	1																				
AU2	2	2	2																				
CrL	Control mode	<ul style="list-style-type: none"> onF : On-off control, When PV=SV, Output stop. When PV<SV-CHY, start output. AI : AI PID control, high precision and the output time proportion can set by parameter Ctl 																					
P	Proportion band	Proportion band in PID with unit ℃	1~999																				
I	Time of integral	Time of integral in PID. No integral effect when I=0	0~999 Sec																				
d	Time of derivative	Time of derivative in PID. No derivative effect when d=0	0~999 Sec																				
Ctl	Control period	Small value can improve control accuracy. For SSR output, generally 0.5 to 3 seconds. For Relay output, generally 15 to 40 seconds, because small value will cause the frequent On-Off of mechanical switch and shorten its service life. Ctl is recommended to be 1/4 – 1/10 of derivative time. When control under on-off control, Ctl use as restart delay time after off, for protect compressor application.	0.5-300 SEC																				
CHY	Control hysteresis	CHY is used for ON-OFF Control. PV > SV, Output turns OFF; PV<SV-CHY, Output turns ON.	0~200																				
InP	Input specification	<table border="1"> <tr> <td>Sn</td> <td>Input spec.</td> <td>Sn</td> <td>Input spec.</td> </tr> <tr> <td>0</td> <td>K</td> <td>1-3</td> <td>Spare</td> </tr> <tr> <td>4</td> <td>E</td> <td>5</td> <td>J</td> </tr> <tr> <td>6</td> <td>Spare</td> <td>7</td> <td>N</td> </tr> <tr> <td>8-20</td> <td>Spare</td> <td>21</td> <td>Pt100</td> </tr> </table>	Sn	Input spec.	Sn	Input spec.	0	K	1-3	Spare	4	E	5	J	6	Spare	7	N	8-20	Spare	21	Pt100	0~21
Sn	Input spec.	Sn	Input spec.																				
0	K	1-3	Spare																				
4	E	5	J																				
6	Spare	7	N																				
8-20	Spare	21	Pt100																				
Scb	Input shift	Scb is used to make input shift to compensate the error produced by sensor or input signal. PV after compensation= PV before compensation + Scb.	-99~+99℃																				

FIL	PV input filter	The value of FIL will determine the ability of filtering noise. When a large value is set, the measurement input is stabilized but the response speed is slow. Generally, it can be set to 1 to 3. If great interference exists, then you can increase parameter "FIL" gradually to make momentary fluctuation of measured value less than 2 to 5. When the instrument is being metrological verified, "FIL" s can be set to 0 or 1 to shorten the response time.	0~40
Fru	Selection of power frequency and temperature scale	50C: 50Hz, °C 50F: 50Hz, °F 60C: 60Hz, °C 60F: 60Hz, °F	
SPH	Upper limit of SV	Maximum value that SV allowed to be. When SPH=400, the SV range will 0~400°C	0~999°C

VI. INSTRUMENT INSTALLATION AND WIRING

Wiring graph for instruments with dimension A, B, E or F

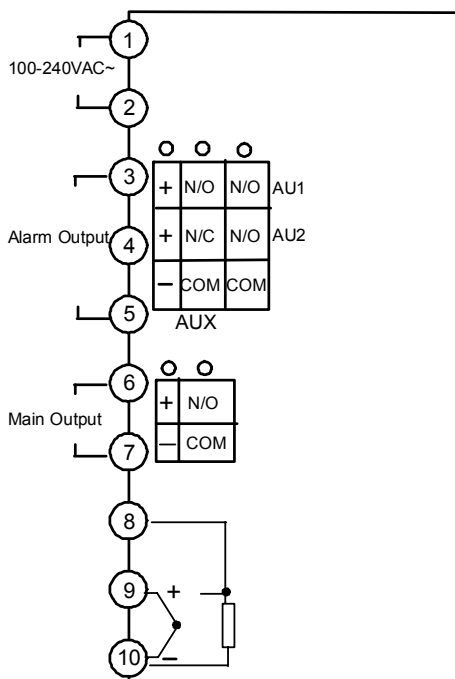

Note: The graph suits for upright instruments with dimension A or E

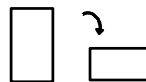

For instruments with dimension B or F size, just clockwise rotate the graph 90 degree.

Wiring graph for D2 dimension (48X48mm) instruments:

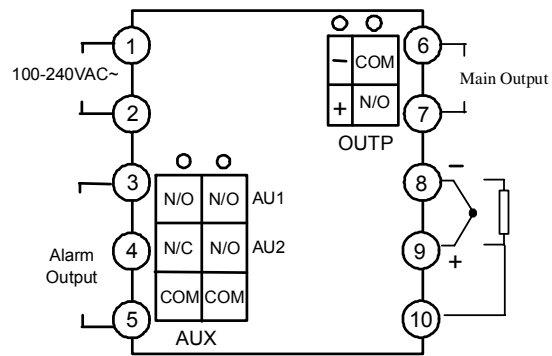

Wiring graph for D dimension (72mmX72mm) instruments

